

Radio system - "Sound System"

General information

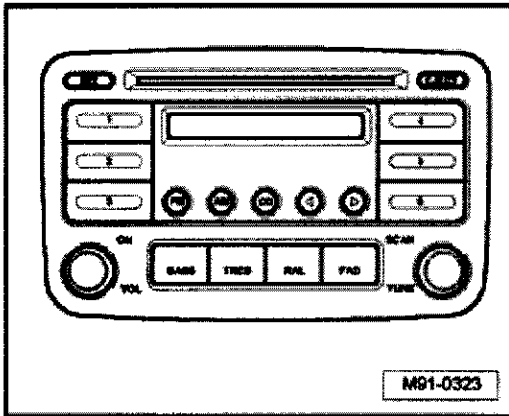

Radio head unit - "Sound System"

Radio system consists of the radio head unit with integrated single CD player, loudspeakers located in front/rear doors and antenna integrated in rear window.

Radio head unit output performance: 4x20 watt

Front loudspeakers: 3-way system.

Rear loudspeakers: 2-way system.

Loudspeaker applications:

Front doors - one bass loudspeaker, one mid-range loudspeaker and one treble loudspeaker on each side.

Rear doors - one bass loudspeaker and one treble loudspeaker on each side.

Integrated CD player plays "MP3", "CD-R" and "CD-RW" formats as well as normal audio CDs.

Note:

Do not use 8 cm diameter "mini disks". Should a "mini disk be inserted, it will not eject and CD player damage will result.

Do not use CDs that contain a mix of computer and music

data. Mixed data CDs cannot be played back.

Before troubleshooting or servicing, technicians must be familiar with the functions and operation specifics of the standard or optional radio system. Always read the owners manual and review applicable system functions.

Note:

Additional information:

⇒ *Owners Manual*

⇒ *Self Study Program - Course Number 89103 "The 2005 new Jetta New Model Introduction"*

⇒ *Self Study Program - Course Number 873403 "The 2005 new Jetta - Electrical System"*

⇒ *Wiring Diagrams Component Locations*

Warning!

When disconnecting and reconnecting battery terminals, observe all applicable Notes and torque specifications, as well as instructions on performing OBD program and electrical system function checks as specified in

⇒ ***Repair Manual, Electrical Equipment, Repair Group 27, Battery, disconnecting and reconnecting***

On Board Diagnostic, functions

Radio system "Sound System" has On Board Diagnostic (OBD) capability. If malfunctions occur in monitored components, Diagnostic Trouble Codes (DTC) will be stored in memory.

Troubleshoot radio system malfunctions by performing OBD program using Vehicle Diagnosis, Testing and Information System VAS 5051/5052/5052 in operating mode "Guided Fault Finding" .

Radio system - "Sound System" ,

component overview

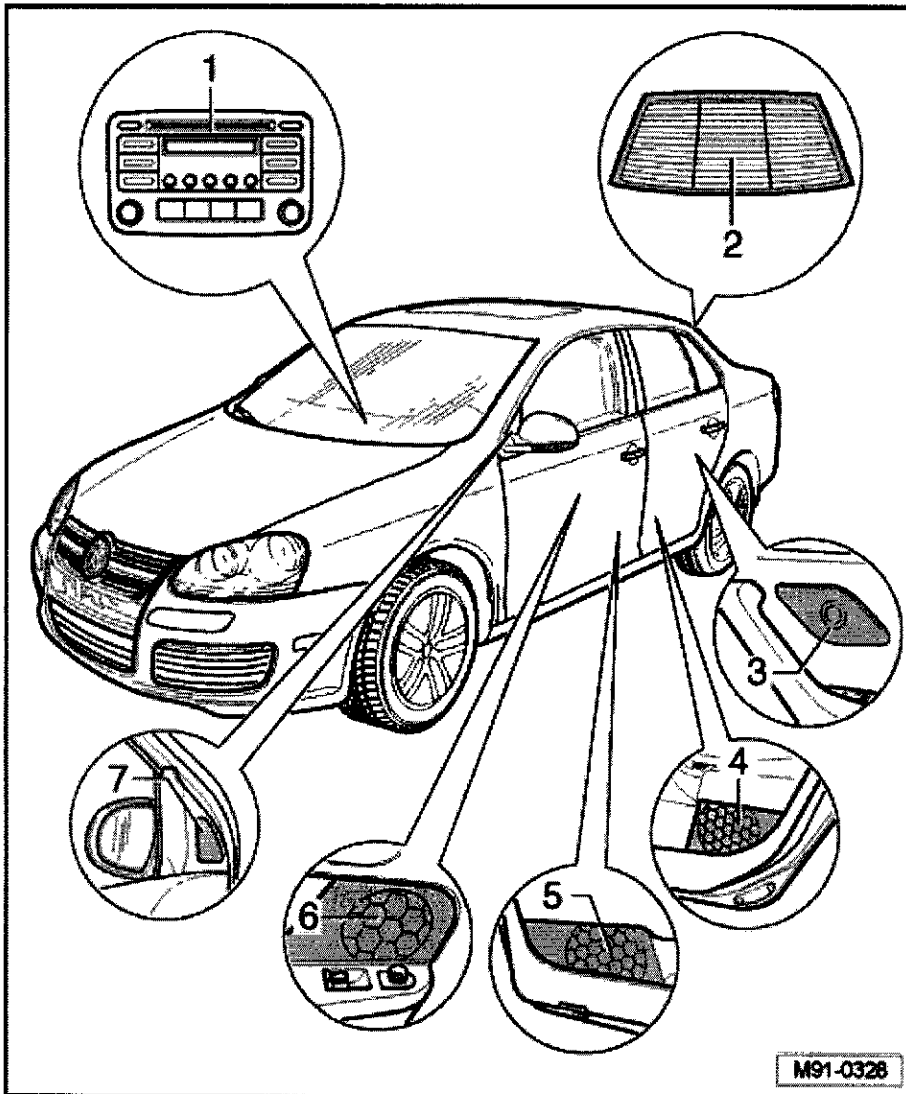

1. Radio R

- Removing and installing ⇒ 91-1, Radio - Sound System , removing and installing

2. Antenna R11

- Installed in rear window
- Additional information ⇒ 91-8, Antenna systems

3. Right Rear Treble Speaker R16 and Left Rear Treble Speaker R14

- Installed in left and right rear door trim

- 4. Right Rear Bass Speaker R17 and Left Rear Bass Speaker R15**
- Installed in left and right rear door trim

- 5. Right Front Bass Speaker R23 and Left Front Bass Speaker R21**
- Installed in left and right front door trim

- 6. Right Front Midrange Speaker R104 and Left Front Midrange Speaker R103**
- Installed in left and right front door trim

- 7. Right Front Treble Speaker R22 and Left Front Treble Speaker R20**
- Installed in both front door mirror triangles

Radio - "Sound System" , removing and installing

Note:

The replacement part number is printed on a sticker on the unit housing. Always confirm proper application.

Before removing radio unit, obtain anti-theft security code from customer. If unit is replaced, ensure anti-theft security code is activated (see owners manual) or ⇒ 91-1, Radio - electronic anti-theft system . Give new code number to customer.

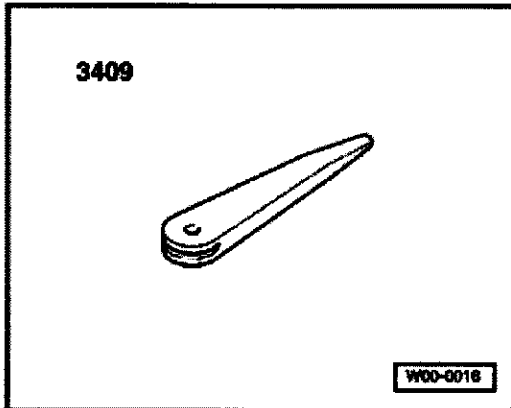

Special tools, testers and auxiliary items required

Trim removal wedge 3409

Removing:

Warning!

Before beginning repairs on electrical system

Switch off all electrical consumers.

Switch ignition off and remove ignition key.

Remove any CDs which may have been left in CD player ⇒ Owners Manual .

- Remove center instrument panel trim with air outlets so that radio panel screws are accessible,

⇒ *Repair Manual, Body Interior, Repair Group 68, Storage compartments, covers and panels*

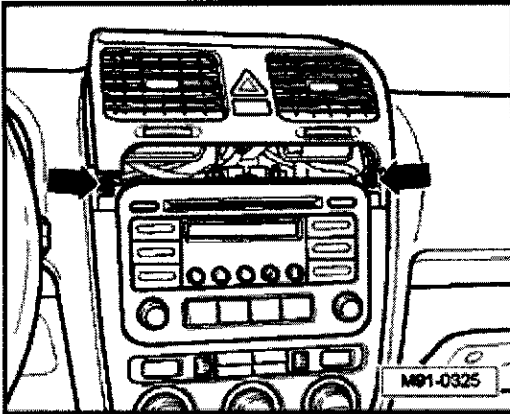

- Remove screws - **arrows** - .

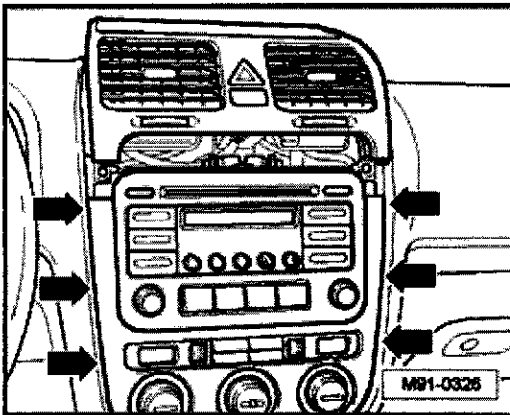

- Use trim removal wedge 3409 to carefully pry out center instrument panel trim in area of - **arrows** - and remove.

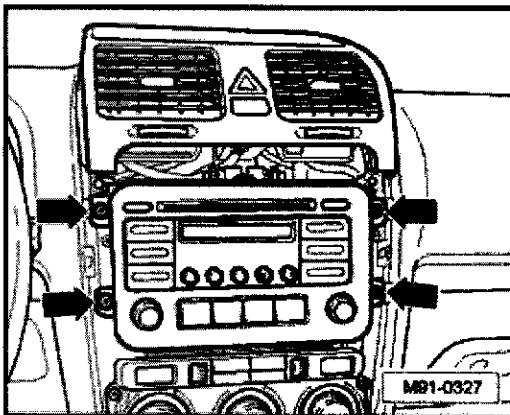

- Remove screws - **arrows** - .

- Pull radio unit from opening until electrical connections on rear of unit are accessible.

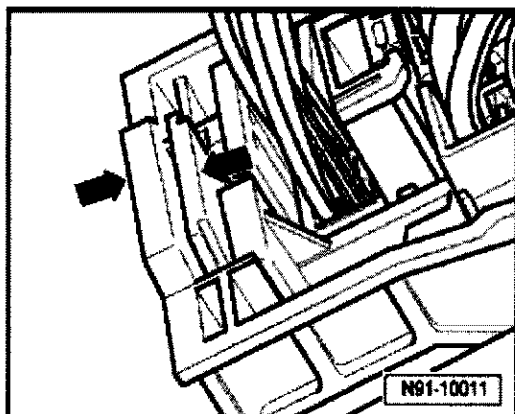

- Disengage electrical connection lock - **arrows** - .

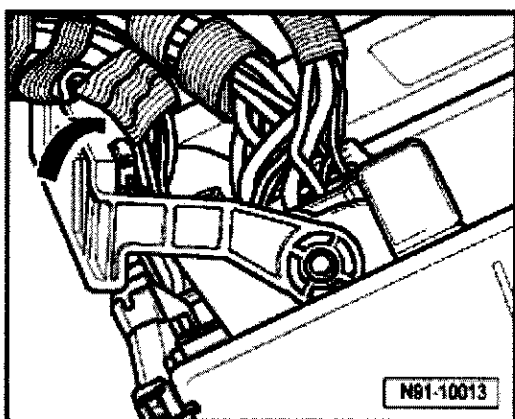

- Rotate mounting bracket up - **arrow** - and disconnect electrical connection.

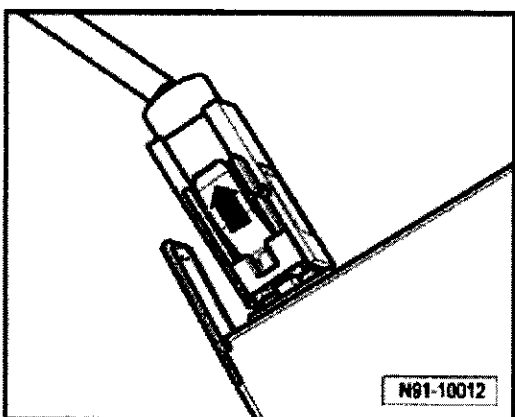

- Disengage antenna cable electrical connection lock - **arrow** - and disconnect.

Installing:

- Reconnect electrical/antenna connections and lock into position.

Warning!

In the event of a collision where occupants may make contact with interior trim, some interior knobs and buttons are designed to break away in a controlled manner in order to protect the occupant. When installing the radio unit, do not press on control buttons or display. Damage will result.

- Slide unit straight into instrument panel opening until it engages in assembly frame.

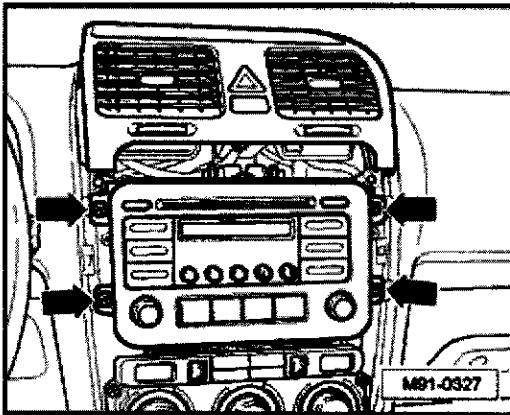

- Install screws - **arrows** - .

- Reinstall center instrument panel trim.

- If necessary, deactivate anti-theft coding, ⇒ 91-1, Radio - electronic anti-theft system .

- Check radio coding, recode if necessary.

Radio unit, coding, ⇒ 91-1, Radio system components, adapting

Multi-pin connector assignments

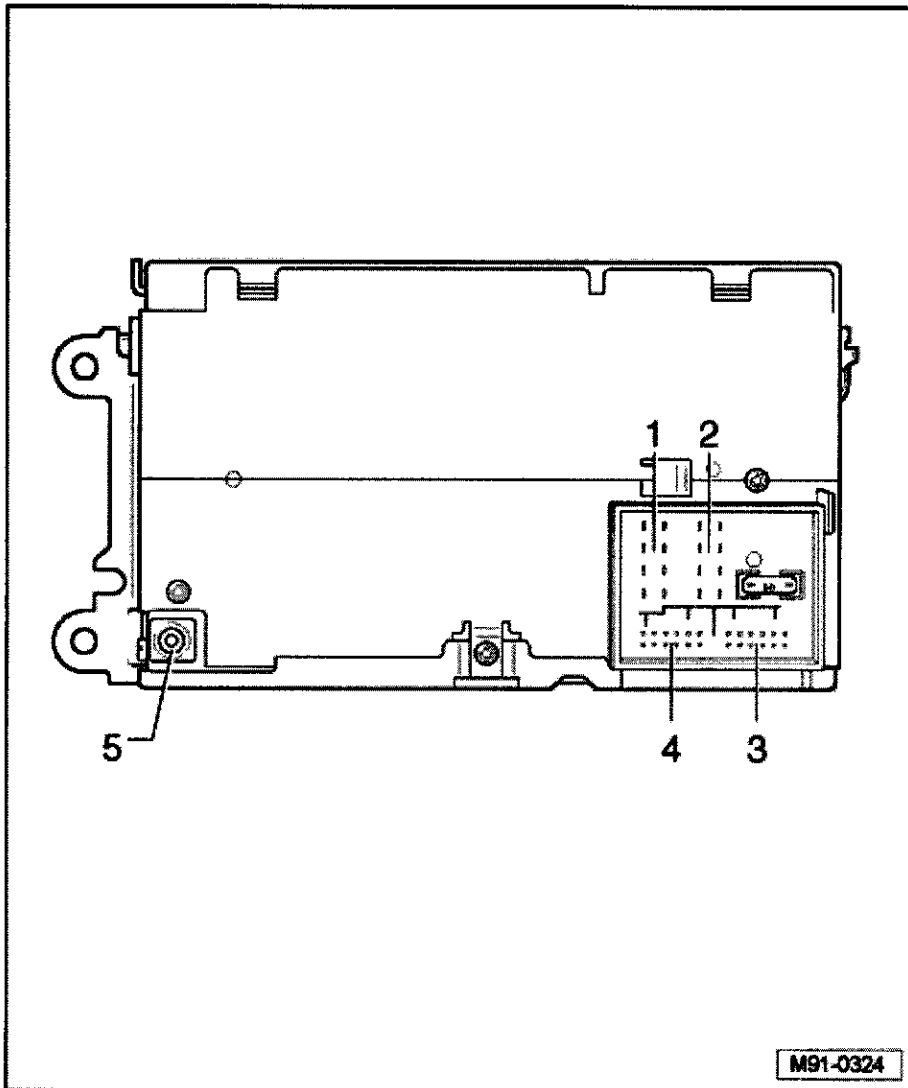

1. 8-pin multi-pin electrical connection 1, loudspeaker outputs

- Terminal assignment, ⇒ 91-1, 8-pin multi-pin electrical connection 1, loudspeaker outputs

2. 8-pin multi-pin electrical connection 2, power supply, CAN-Bus

- Terminal assignment, ⇒ 91-1, 8-pin multi-pin electrical connection 2, power supply, CAN-Bus

3. 12-pin multi-pin electrical

connection 3, telephone signal input (where applicable)

- Terminal assignment, ⇒ 91-1, 12-pin multi-pin electrical connection 3, telephone signal input (where applicable)

4. Multi-pin electrical connection 4

- Not assigned

5. electrical connection 5, antenna connection

- Connection for antenna wire to antenna in rear window

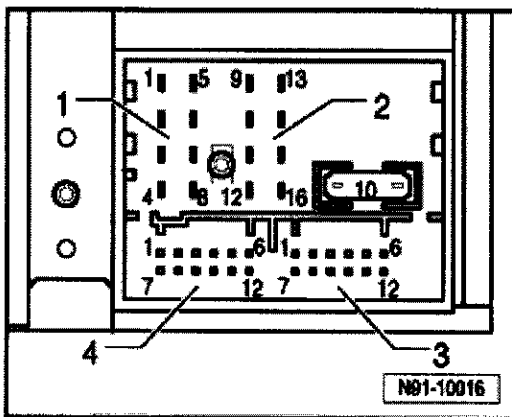

8-pin multi-pin electrical connection 1, loudspeaker outputs

- 1 - Right rear loudspeaker, plus
- 2 - Right front loudspeaker, plus
- 3 - Left front loudspeaker, plus
- 4 - Left rear loudspeaker, plus
- 5 - Right rear loudspeaker, minus
- 6 - Right front loudspeaker, minus
- 7 - Left front loudspeaker, minus
- 8 - Left rear loudspeaker, minus

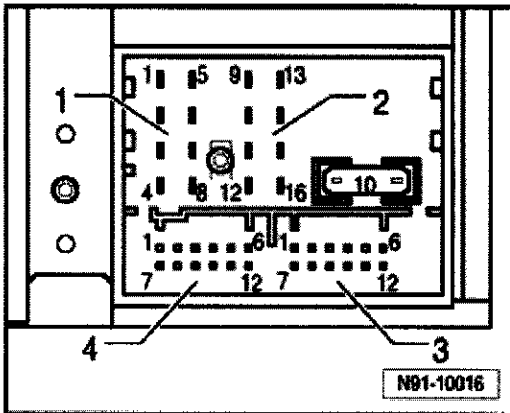

8-pin multi-pin electrical connection 2, power supply, CAN-Bus

- 9 - CAN-Bus, plus
- 10 - CAN-Bus, minus
- 11 - Telephone muting (where applicable)
- 12 - Ground (Terminal 31)
- 13 - Radio on, control wire
- 14 - Alarm contact
- 15 - Plus connection (Terminal 30)
- 16 - Control signal for anti-theft system, SAFE, terminal 30

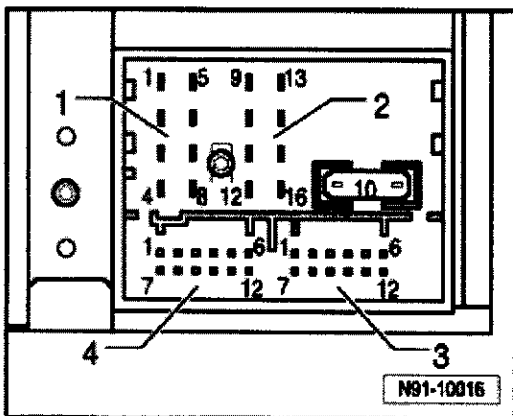

12-pin multi-pin electrical connection 3, telephone signal input (where applicable)

Note:

Electrical connection where applicable.

- 15 - Not assigned

6 - Telephone LF-signal input, minus

711 - Not assigned

12 - Telephone LF-signal input, plus

Radio - electronic anti-theft system

Radio - "Sound System" is equipped with an electronic Comfort anti-theft system which operates in conjunction with radio unit identification data stored in the instrument cluster.

When an existing radio is removed (radio power supply disconnected) and reinstalled in the same vehicle, it is not necessary to input the anti-theft security code.

Electronic anti-theft system, function

After first activation of electronic anti-theft system, a numeric code is stored in both the radio unit and instrument cluster. When the radio power supply is restored (e.g. after removing and installing radio or battery), a data exchange takes place between the radio and instrument cluster.

The data exchange compares the numeric code of the radio unit to the numeric code stored in the instrument cluster. If numeric code is identical, the instrument cluster recognizes that the radio "belongs to the vehicle" and is ready for operation.

Should a radio be replaced, the anti-theft code must be entered.

Deactivating electronic anti-theft system, ⇒ 91-1,
Electronic anti-theft system, deactivating .

Next, when the ignition key is inserted into the ignition switch ("S-contact" activated), the data exchange between the replacement radio and instrument cluster take place automatically.

The data exchange lasts about 5 seconds. During this time a VAS 5051/5052/5052 must not be connected or remain connected.

After successful data exchange, the replacement radio unit is ready for operation without renewed input of anti-theft code (should power supply subsequently be disconnected and reconnected).

The electronic anti-theft system is activated and will lock

the radio as soon as:

radio unit is installed in a different vehicle

instrument cluster is replaced

A radio which has been locked by the electronic anti-theft system will show "SAFE" and "1000" on display when switched on.

To cancel lock, deactivate electronic anti-theft warning system, ⇒ 91-1, Electronic anti-theft system, deactivating .

Electronic anti-theft system, deactivating

Reactivating a locked radio is only possible by entering correct code number for electronic anti-theft system.

Note:

Code number for electronic anti-theft system is listed along with radio serial number on radio card, ⇒ operating instructions .

For security reasons, radio card should not be stored in the vehicle. Obtain the code number from the customer, if necessary.

If a radio is replaced, code number from replacement radio must be used.

Inform the customer that the code number has changed.

- Obtain radio code number.

- Switch on radio unit.

Radio displays "SAFE" and then "1000" . No button inputs are required.

- Using station buttons -1- to -4-, enter code number affixed to radio card. Press preset button 1 to enter first digit of code number, preset button 2 for second digit and so on.

- Then press the **Arrow** button, which is located above the **FAD** button and hold it firmly until the anti-theft coding is activated. This is indicated by a short signal sound.

If the code number has been entered correctly into radio unit, a radio frequency appears on the display.

Note:

If the anti-theft code has been entered incorrectly, it can be corrected immediately in another attempt. If anti-theft code is entered incorrectly twice, then the radio unit is locked for an hour. Radio unit can then be switched on and insert ignition key in ignition lock. After one hour, then the procedure for deactivating the electronic anti-theft system can be repeated. Remember: Always two attempts to input code, after that the radio unit is locked for one hour.

Radio system components, adapting

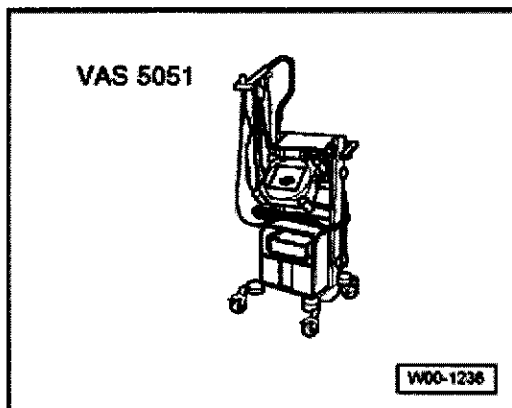

Special tools, testers and auxiliary items required

Vehicle Diagnostic Testing and Information System VAS 5051/5052

Diagnostic cable VAS5051/5a or VAS5051/6a or VAS5052/3

- Select operating mode "Guided Functions" and follow tester prompts

or

- Select operating mode "Guided Fault Finding"

- Enter information as prompted and press ">" to confirm.

After the DTC memory of all control modules has been

Volkswagen Jetta 05> - Communication

checked:

- Press "Go to" button.
- Select "Function/component selection"
- Select "Body (Repair Group 01; 27; 50-97)"
- Select "Electrical system int/ext (Repair Group 01; 27' 90-97)"
- Select "01 - Self diagnosis"
- Select "46 - Sound system"
- Select "Functions" .
- Select appropriate option
- Press ">" to confirm
- Follow tester prompts